

PFAFF

481-G

Unterklassen-Ausstattung

Subclass parts

Composition des sous-classes

Composición de las subclases

22.01

Table of subclasses
Table de sous-classes
Tabla de subclases

PFAFF 481-G

Unterklasse Subclass Sous-classe Subclase	-6/01 (-900/..)	-6/01 (-900/..)	-6/01 (-900/..)	-8/01 (-900/..)
Arbeitsgang Operation Opération Operación	Für allgemeine Näharbeiten. Standardform des Teilesatzes. For ordinary sewing operations. Standard part set. Travaux d'utilité courante. Jeu de pièces standard. Para trabajos de costura en general. Juego de piezas estándar.	Für allgemeine Näharbeiten. Standardform des Teilesatzes. For ordinary sewing operations. Standard part set. Travaux d'utilité courante. Jeu de pièces standard. Para trabajos de costura en general. Juego de piezas estándar.	Für allgemeine Näharbeiten. Standardform des Teilesatzes. For ordinary sewing operations. Standard part set. Travaux d'utilité courante. Jeu de pièces standard. Para trabajos de costura en general. Juego de piezas estándar.	Universalteilesatz, zum Nähen mittlerer Materialien. Universal part set for sewing medium-weight materials. Jeu de pièces universel, pour matières moyennes. Juego de piezas universal para coser géneros semipesados.
Ausführung Model Version Tipo de máquina	B	BN	CN	B
Saumbreite in mm Hem width in mm Largeur de l'ourlet en mm Anchura del dobladillo en mm				
Schneidabstand in mm Trimming margin in mm Distance de coupe en mm Margen de corte en mm				
Absteppbreite Stitching margin Relarge de couture Margen de costura				
Nadelstange Needle bar Barre à aiguille Barra de aguja	91-171 018-91	91-171 018-91	91-171 018-91	91-171 018-91
Nähfuß ⁴ Presser foot Pied presseur Pie prensatelas	91-054 839-23	91-055 959-23	91-055 959-23	91-154 172-21
Rollfuß ⁴ Roller presser Pied à roulette Pie rodante				
Stichplatte ⁴ Needle plate Plaque à aiguille Placa de aguja	91-058 356-25	91-058 579-25	91-058 579-25	91-150 315-25
Stoffschieber ⁴ Feed dog Griffe Transportador inferior	91-059 843-04	91-059 841-04	91-059 841-04	91-059 816-05
Fingerschutz Finger guard Protège-doigts Salvadedos				
Lineal Edge guide Guide-droit Guia recta				
Apparat ⁵ Attachment Appareil Aparato				
Träger Bracket Support Soporte				
Messer ^{9/2} Knife Couteau Cuchilla				
Abdeckplatte Cover plate Plaques de recouvrement Placa cubierta				
Niederhalter Work retainer Pied de maintien Pie de retención				

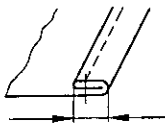
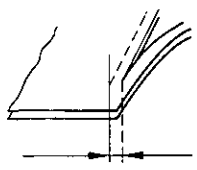
Unterklasse Subclass Sous-classe Subclase	-19/27 (-900/..)	-34/02 (-900/..)	-55/01 (-900/..)	-731/11 (/12) -2/99 (-900/..) ■
Arbeitsgang Operation Opération Operación		Zum Nähen besonders feiner Stoffe mittels Brücken-Teilesatz. For stitching delicate fabrics with bridge-type part set. Couture de tissus particulièrement fins; jeu de pièces en pont. Para géneros muy finos mediante juego de piezas en puente.	Für allgemeine Näharbeiten an Leder, Kunstleder, Moltopren usw. mittels ausschwenkbarem Rollfuß. For ordinary sewing operations on leather, leatherette, moltoprene etc. Retractable roller presser. Travaux de couture courants sur cuir, similicuir, moltopréne, etc. Pied à roulette relevable. Para trabajos de costura general sobre cuero, cuero sintético, moltopren, etc., mediante pie rodante levadizo.	
Ausführung Model Version Tipo de máquina	CN	A	B	B
Saumbreite in mm Hem width in mm Largeur de l'ourlet en mm Anchura del dobladillo en mm	15; 20; 30			
Schneidabstand in mm Trimming margin in mm Distance de coupe en mm Margen de corte en mm				4,0; 5,0
Absteppbreite Stitching margin Relarge de couture Margen de costura				
Nadelstange Needle bar Barre à aiguille Barra de aguja	91-171 018-91	91-171 018-91	91-171 663-92	91-171 663-92
Nähfuß [4] Presser foot Pied presseur Pie prensatelas	91-057 676-03 x 13 [5] [13] = 15 mm 91-057 678-93 x 18 [5] [13] = 20 mm 91-057 678-93 x 28 [5] [13] = 30 mm	91-054 841-23		91-057 346-04
Rollfuß [4] Roller presser Pied à roulette Pie rodante			91-051 926-93	
Stichplatte [4] Needle plate Plaque à aiguille Placa de aguja	91-058 579-25	91-058 456-25	91-058 188-05	91-058 803-93
Stoffschieber [4] Feed dog Griffe Transportador inferior	91-059 841-04	91-059 838-04	91-059 836-04	91-059 832-04
Fingerschutz Finger guard Protège-doigts Salvadedos				91-055 189-25
Lineal Edge guide Guide-droit Guía recta				91-057 342-91
Apparat [5] Attachment Appareil Aparato	91-056 602-93			
Träger Bracket Support Soporte	91-753 936-90			
Messer [92] Knife Couteau Cuchilla				91-169 395-04 x 7 [5] = 4,0; 5,0 mm
Abdeckplatte Cover plate Plaque de recouvrement Placa cubierta				91-172 918-05
Niederhalter Work retainer Pied de maintien Pie de retención				

22.01

Table of subclasses
Table de sous-classes
Tabla de subclases



PFAFF 481-G

Unterklasse Subclass Sous-classe Subclase	-731/11 (/12)-6/01	-731/11 (/12)-6/01 -900/..	-731/11 (/12)-6/01 (-900/..)	-731/14-6/01 (-900/..)
Arbeitsgang Operation Opération Operación				
Ausführung Model Version Tipo de máquina	B	B	B	B
Saumbreite in mm Hem width in mm Largeur de l'ourlet en mm Anchura del dobladillo en mm				
Schneidabstand in mm Trimming margin in mm Distance de coupe en mm Margen de corte en mm	2,5 - 3,5	2,5 - 3,5	4,0 - 12,0	5,0
Absteppbreite Stitching margin Relarge de couture Margen de costura				
Nadelstange Needle bar Barre à aiguille Barra de aguja	91-171 663-92	91-171 663-92	91-171 663-92	91-171 663-92
Nähfuß ⁴ Presser foot Pied presseur Pie prensatelas	91-054 426-03	91-054 426-03	91-054 426-03	91-054 426-03
Rollfuß ⁴ Roller presser Pied à roulette Pie rodante				
Stichplatte ⁴ Needle plate Plaque à aiguille Placa de aguja	91-158 507-93	91-058 176-93	91-158 507-93	91-158 507-93
Stoffschieber ⁴ Feed dog Griffe Transportador inferior	91-059 645-04	91-047 621-04	91-059 645-04	91-059 645-04
Fingerschutz Finger guard Protège-doigts Salvadedos				
Lineal Edge guide Guide-droit Guía recta				
Apparat ⁵ Attachment Appareil Aparato				
Träger Bracket Support Soporte				
Messer ^{9/2} Knife Couteau Cuchilla	91-169 395-04 x 7 ⁹ = 2,5 - 3,5 mm	91-169 395-04 x 7 ⁹ = 2,5 - 3,5 mm	91-169 395-04 x 7 ⁹ = 4,0 - 5,0 mm 91-170 560-04 x 9 ⁹ = 6,0 - 12,0 mm	91-165 629-05
Abdeckplatte Cover plate Plaque de recouvrement Placa cubierta				
Niederhalter Work retainer Pied de maintien Pie de retención				

Unterklasse Subclass Sous-classe Subclase	-748/...-8/01 (-900/...)	-780/04-2/06-900/51-980/07
Arbeitsgang Operation Opération Operación	Universalteilesatz, zum Nähen mittlerer Materialien. Universal part set for sewing medium-weight materials. Jeu de pièces universel, pour matières moyennes. Juego de piezas universal para coser géneros semipesados.	Für rechte Kantennäharbeiten. Nähfuß mit seitlich verstellbarem Lineal. Sensorenabstand zur Nadelmitte 28 mm. For marginal stitching operations (right fabric edge). Presser foot with laterally adjustable edge guide. Clearance between sensor and needle centre 28 mm. Coutures au bord droit. Pied à guide-bord réglable latéralement. Ecartement détecteur - axe de l'aiguille 28 mm. Para costuras marginales a la derecha. Pie prensatelas con guía regulable lateralmente. Distancia del sensor al centro de la aguja 28 mm.
Ausführung Model Version Tipo de máquina	B	AN 3,5
Saumbreite in mm Hem width in mm Largeur de l'ourlet en mm Anchura del dobladillo en mm		
Schneidabstand in mm Trimming margin in mm Distance de coupe en mm Margen de corte en mm		
Absteppbreite Stitching margin Retarge de couture Margen de costura		1,5 - 7,0
Nadelstange Needle bar Barre à aiguille Barra de aguja	91-171 663-92	91-171 663-92
Nähfuß ⁴ Presser foot Pied presseur Pie prensatelas	91-154 495-23	91-155 654-91
Rollfuß ⁴ Roller presser Pied à roulette Pie rodante		
Stichplatte ⁴ Needle plate Plaque à aiguille Placa de aguja	91-150 315-25	91-158 950-91 ¹² = 1,5 - 7,0 mm
Stoffschieber ⁴ Feed dog Griffe Transportador inferior	91-059 816-05	91-059 806-04
Fingerschutz Finger guard Protège-doigts Salvededos		
Lineal Edge guide Guide-droit Guía recta		
Apparat ⁵ Attachment Appareil Aparato		
Träger Bracket Support Soporte		
Messer ^{9/2} Knife Couteau Cuchilla		
Abdeckplatte Cover plate Plaque de recouvrement Placa cubierta		
Niederhalter Work retainer Pied de maintien Pie de retención		91-155 909-01

22.02

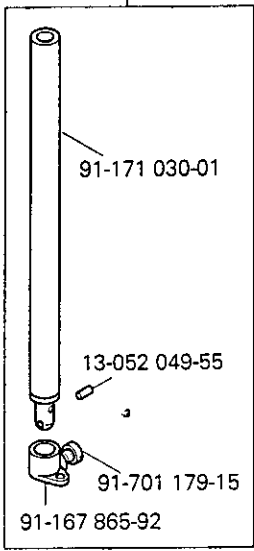
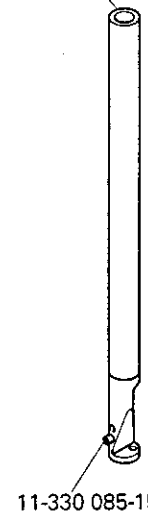
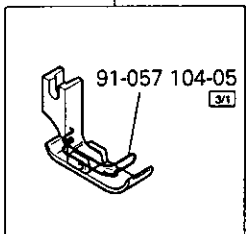
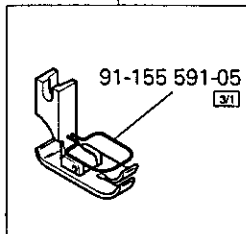
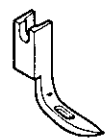
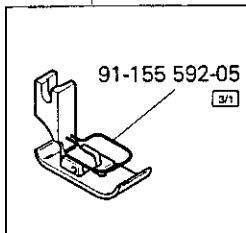
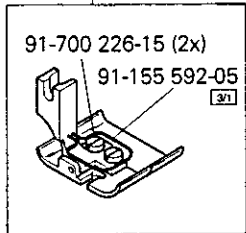

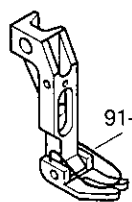
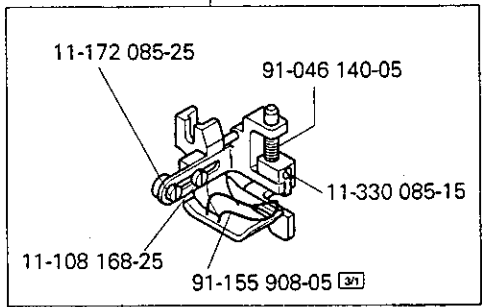

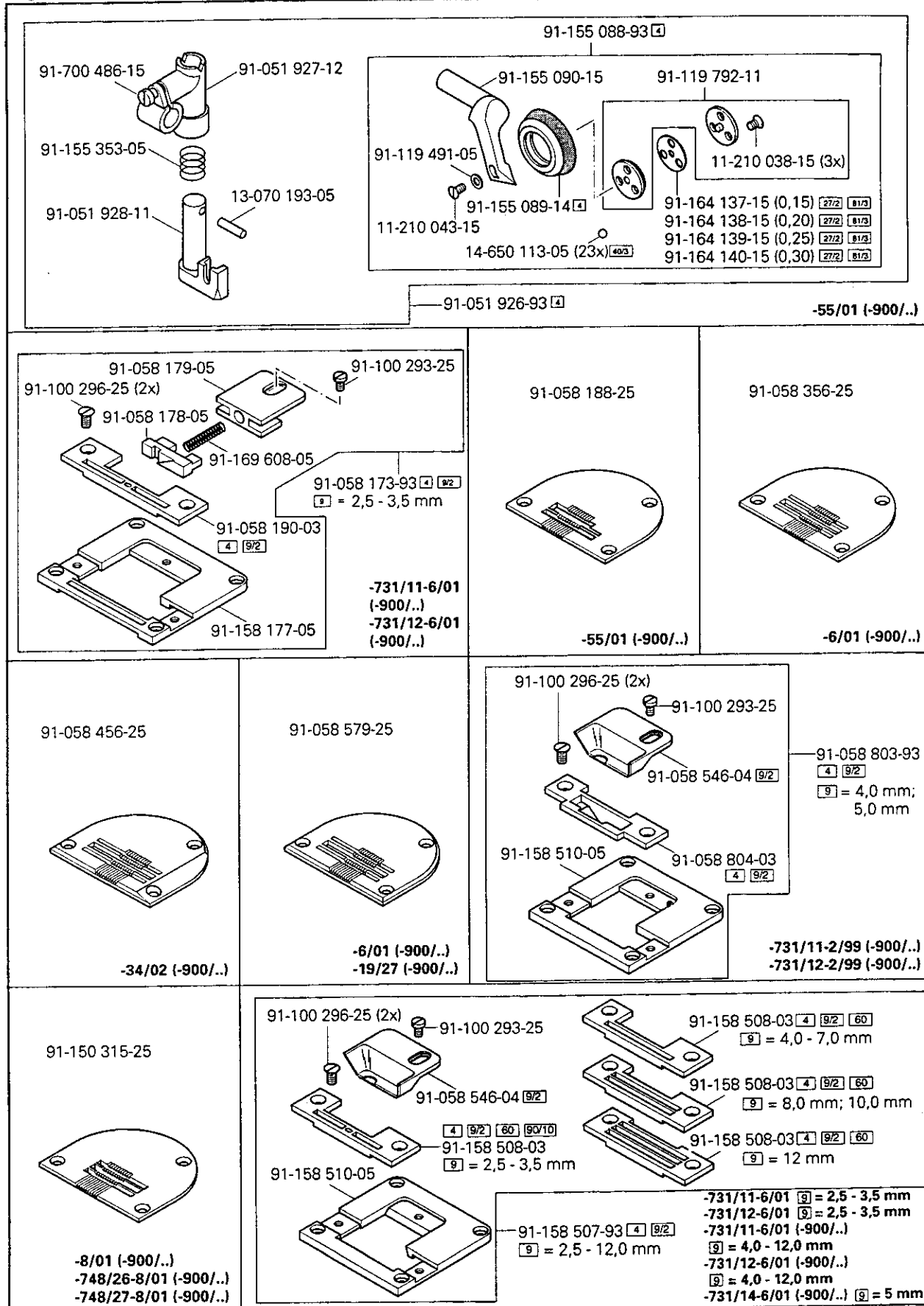





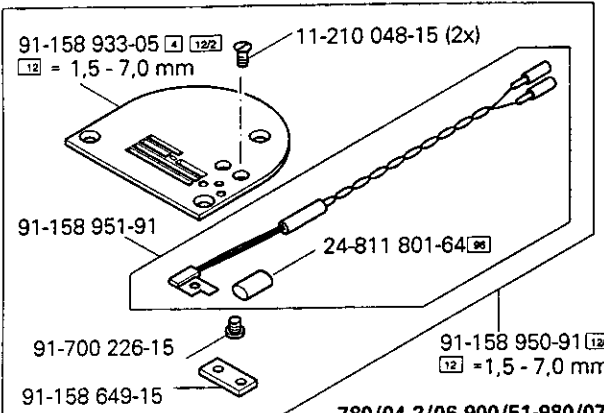







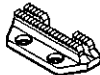











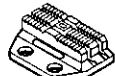

Gauge parts
 Organes de couture
 Organos de costura PFAFF 481-G

<p>91-171 018-91</p>  <p>91-171 030-01</p> <p>13-052 049-55</p> <p>91-701 179-15</p> <p>91-167 865-92</p> <p>-6/01 (-900/..) -8/01 (-900/..) -19/27 (-900/..) -34/02 (-900/..)</p>	<p>91-171 663-92</p>  <p>11-330 085-15</p> <p>-55/01 (-900/..) -731/11-2/99 (-900/..) -731/12-2/99 (-900/..) -731/11-6/01 (-900/..) -731/12-6/01 (-900/..) -731/14-6/01 (-900/..) -748/26-8/01 (-900/..) -748/27-8/01 (-900/..) -780/04-2/06-900/51-980/02</p>	<p>91-054 426-03 4 92</p>  <p>91-057 104-05 3/1</p> <p>9 = 2,5 - 12,0 mm -731/11-6/01 (-900/..) -731/12-6/01 (-900/..) -731/14-6/01 (-900/..)</p>	<p>91-054 839-23 4</p>  <p>91-155 591-05 3/1</p> <p>-6/01 (-900/..)</p>
<p>91-057 346-04 4</p>  <p>-731/11-2/99 (-900/..) -731/12-2/99 (-900/..)</p>	<p>91-057 676-03 x 13 4 5</p> <p>13 = 15 mm</p>  <p>91-155 592-05 3/1</p> <p>-19/27 (-900/..)</p>	<p>91-057 678-93 x 18 4 5</p> <p>13 = 20 mm</p> <p>91-057 678-93 x 28 4 5</p> <p>13 = 30 mm</p>  <p>91-700 226-15 (2x)</p> <p>91-155 592-05 3/1</p> <p>-19/27 (-900/..)</p>	<p>91-154 172-21</p>  <p>91-155 591-05 3/1</p> <p>-8/01 (-900/..)</p>
<p>91-154 495-23 4</p>  <p>91-054 894-05 3/1</p> <p>-748/26-8/01 (-900/..) -748/27-8/01 (-900/..)</p>	<p>91-155 654-91</p>  <p>11-172 085-25</p> <p>91-046 140-05</p> <p>11-330 085-15</p> <p>11-108 168-25</p> <p>91-155 908-05 3/1</p> <p>-780/04-2/06-900/51-980/07</p>		

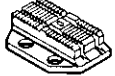

22.02

Gauge parts
 Organes de couture
 Organos de costura PFAFF 481-G

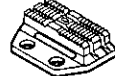
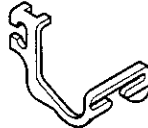
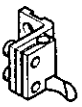
 <p>91-158 933-05  122  = 1,5 - 7,0 mm</p> <p>11-210 048-15 (2x)</p> <p>91-158 951-91</p> <p>24-811 801-64 </p> <p>91-700 226-15</p> <p>91-158 649-15</p> <p>91-158 950-91  122  = 1,5 - 7,0 mm</p> <p>-780/04-2/06-900/51-980/07</p>	<p>91-047 621-04  92  = 2,5 - 3,5 mm</p>  <p>-731/11-6/01 (-900/..) -731/12-6/01 (-900/..)</p>	<p>91-059 645-04  92  = 2,5 - 3,5 mm</p>  <p>-731/11-6/01 (-900/..) -731/12-6/01 (-900/..)</p>	
<p>91-059 645-04  92  = 4,0 - 7,0 mm</p>  <p>-731/11-6/01 (-900/..) -731/12-6/01 (-900/..) -731/14-6/01 (-900/..)</p>	<p>91-059 645-04  92  = 8,0 mm; 10,0 mm</p>  <p>-731/11-6/01 (-900/..) -731/12-6/01 (-900/..)</p>	<p>91-059 645-04  92  = 12,0 mm</p>  <p>-731/11-6/01 (-900/..) -731/12-6/01 (-900/..)</p>	<p>91-059 806-04 </p>  <p>-780/04-2/06-900/51-980/07</p>
<p>91-059 816-05</p>  <p>-8/01 (-900/..) -748/26-8/01 (-900/..) -748/27-8/01 (-900/..)</p>	<p>91-059 832-04  92  = 4,0 mm; 5,0 mm</p>  <p>-731/11-2/99 (-900/..) -731/12-2/99 (-900/..)</p>	<p>91-059 836-04 </p>  <p>-55/01 (-900/..)</p>	<p>91-059 838-04 </p>  <p>-34/02 (-900/..)</p>
<p>91-059 841-04 </p>  <p>-6/01 (-900/..) -19/27 (-900/..)</p>	<p>91-059 843-04 </p>  <p>-6/01 (-900/..)</p>	<p>91-055 189-25</p>  <p>-731/11-2/99 (-900/..) -731/12-2/99 (-900/..)</p>	<p>91-057 342-91</p>  <p>-731/11-2/99 (-900/..) -731/12-2/99 (-900/..)</p>

91-165 629-05

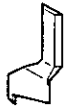

-731/14-6/01 (-900/..)

91-169 395-04 x 7 $\frac{9}{2}$
 $\frac{9}{2}$ = 2,5 - 5,0 mm



-731/11-2/99 (-900/..)
 -731/12-2/99 (-900/..)
 -731/11-6/01 (-900/..)
 -731/12-6/01 (-900/..)

91-170 560-04 x 9 $\frac{9}{2}$
 $\frac{9}{2}$ = 6,0 - 12,0 mm



-731/11-6/01 (-900/..)
 -731/12-6/01 (-900/..)

91-753 936-90

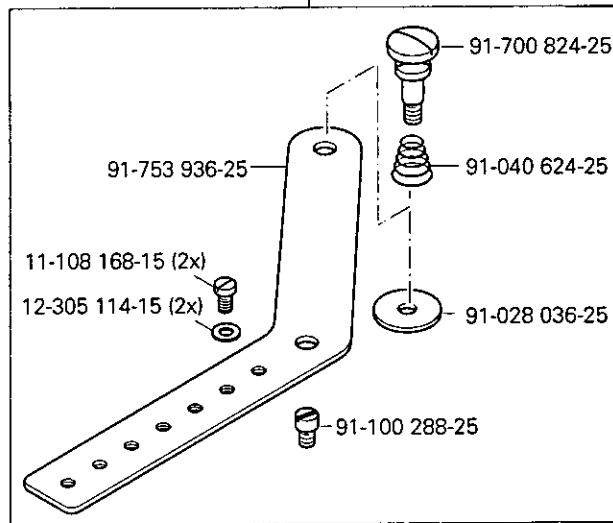

-19/27 (-900/..)

91-172 918-05

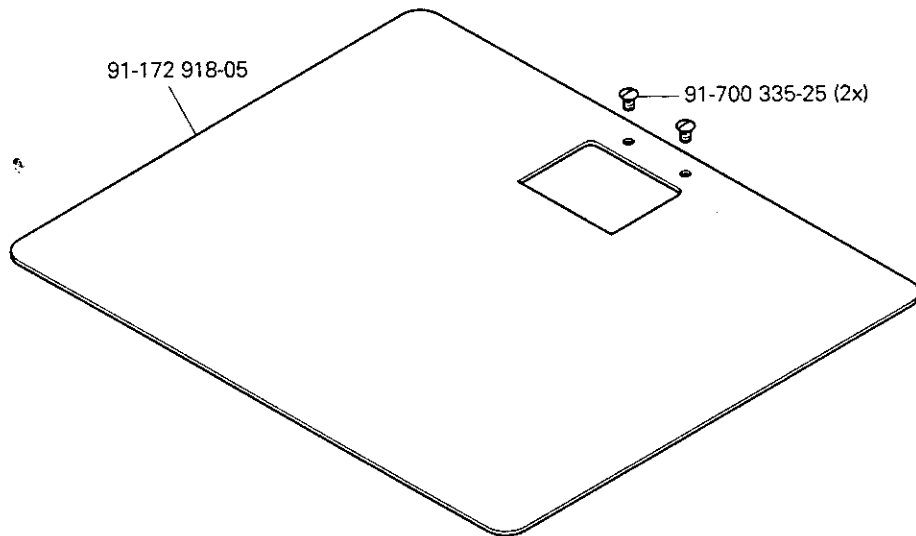

-731/11-2/99 (-900/..)
 -731/12-2/99 (-900/..)

91-056 602-93 $\frac{5}{2}$ 11-210 081-15 (4x)

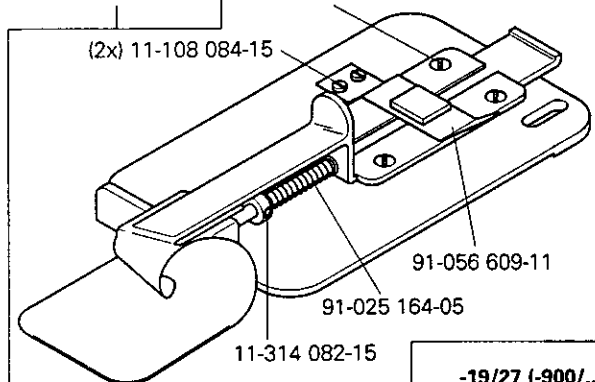

-19/27 (-900/..)

91-155 909-91

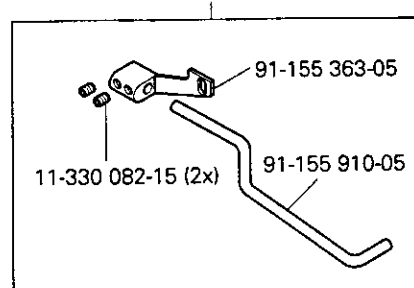

-780/04-2/06-900/51-980/07